

## Adjustable pull ring with quick release, galvanised

Diameter:  $\varnothing$  80 –  $\varnothing$ 500 mm

The adjustable pull ring (fb.) is an efficient pull ring with an innovative snap lock that enables quick and hassle-free installation of industrial pipework and extraction systems. This pull ring is ideal for transporting various materials such as wood shavings, plastic granules and grains.

Designed specifically for pipes with a material thickness of 0.7 - 1.25 mm, the pull ring is characterised by its simple yet powerful mechanism. The pull ring is fitted around the two edges and secured with an adjustable snap lock that not only guarantees a solid connection, but also allows for easy and convenient customisation.

Pull rings are electro-galvanised.

EPDM rubber rings are available as an optional extra for sealing  $\varnothing$  80 -  $\varnothing$  300 mm assemblies.

They are supplied in plastic bags of 10.

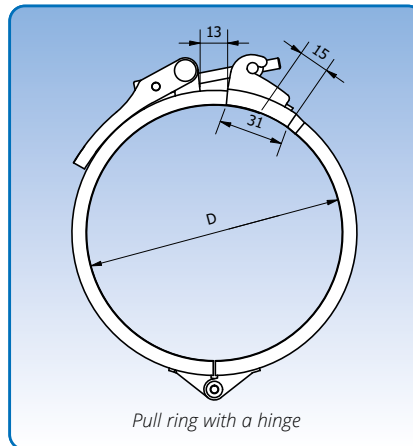

*Pull ring with a hinge*

From  $\varnothing$  80 mm up to  $\varnothing$  125 mm with an adjustable handle and hinge

Pull ring with a hinge		
Item no.	D mm	Pcs. Weight kg
82921080	80	0,11
82921100	100	0,12
82921120	120	0,13
82921125	125	0,14

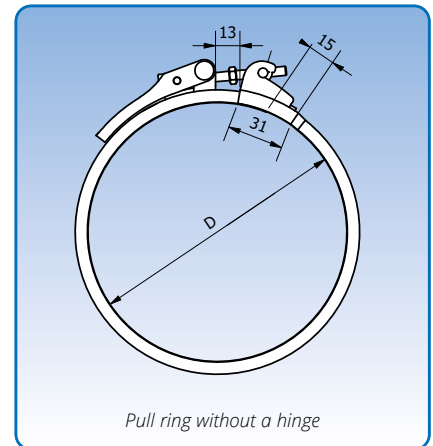

*Pull ring without a hinge*

From  $\varnothing$  140 mm up to 500 mm with an adjustable handle, without a hinge.

Pull ring without a hinge		
Item no.	D mm	Pcs. Weight kg
82920140	140	0,13
82920150	150	0,13
82920160	160	0,14
82920180	180	0,15
82920200	200	0,16
82920225	225	0,18
82920250	250	0,18
82920300	300	0,20
82920315	315	0,21
82920350	350	0,21
82920400	400	0,25
82920450	450	0,27
82920500	500	0,28