

## 45° branch plates, galvanised

Diameter: ø80 – ø1000 mm.

Galvanised branch plates are made of 0.90 mm sheet metal.

State A-, B- and C dimensions when ordering.  
Options are limited by  $A = C$ , and  $A \geq B$ .  
 $A = C$  must be max. 1000 mm.

The branch determines the length of L1.  
Branch plates are always straight with the branch centrally located.

If  $B < 300$ :  $X = 50$  mm  
If  $B > 300$ :  $X = 100$  mm

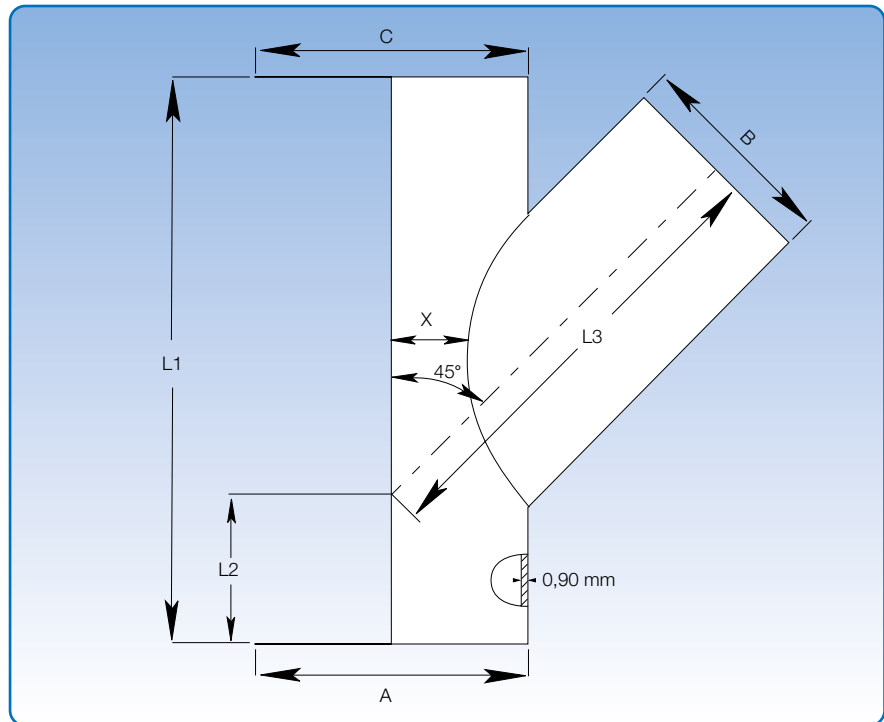

### Calculating L2 and L3:

$L1 =$  see table

$$L2 = \frac{1}{2} \times \left( L1 - \frac{A}{\tan \alpha} \right)$$

$$L3 = \frac{L1 - L2}{\cos \alpha} - \left( \frac{B}{2} \times \tan \alpha \right)$$

### Example:

$A = 550$ ,  $B = 500$ ,  $C = 550$

$L1 = 1050$  mm

$$L2 = 0,5 \times \left( 1050 - \frac{550}{\tan 44,8} \right) = 0,5 \times (1050 - 550)$$

$L2 = 248,07$  p 248 mm

$$L3 = \frac{1050 - 248}{\cos 44,8} - \left( \frac{500}{2} \times \tan 44,8 \right) = 1130,26 - 248,26$$

$L3 = 882$  mm

Dimensions					
A = C mm	B mm	L1 mm	L2 mm	L3 mm	$\alpha$
Select (80 - 1000)	80	300	Calculate	Calculate	43,8
	100	300			43,8
	120	350			44,0
	125	350			44,0
	140	350			44,1
	150	400			44,2
	160	400			44,2
	180	400			44,3
	200	450			44,4
	225	500			44,5
	250	500			44,5
	275	600			44,6
	300	600			44,6
	315	600			44,6
	350	700			44,7
	400	800			44,7
	450	950			44,7
	500	1050			44,8
	550	1150			44,8
	600	1150			44,8
650	1150	44,8			
700	1300	44,8			
750	1300	44,8			
800	1450	44,8			
850	1450	44,9			
900	1650	44,9			